

DWG. NO. D0100009		SHT. 1-1	REV. B
REVISIONS			
REV.	E.C.D.	DESCRIPTION	DATE BY APP'D
B	0857	REDRAWN TO COMPUTER	08/18/93 EL JK

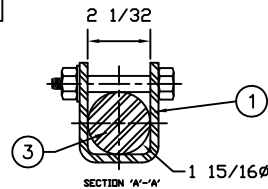
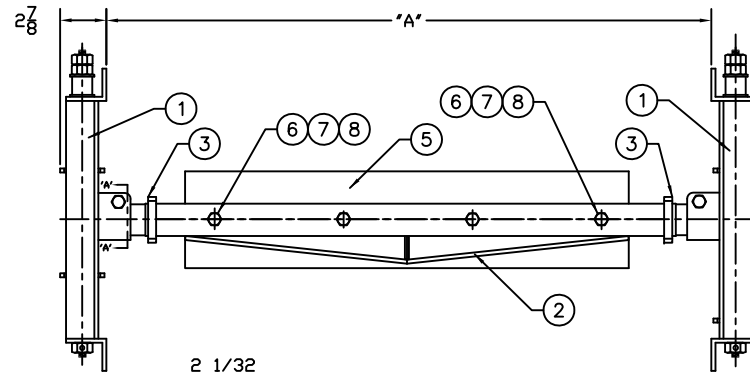
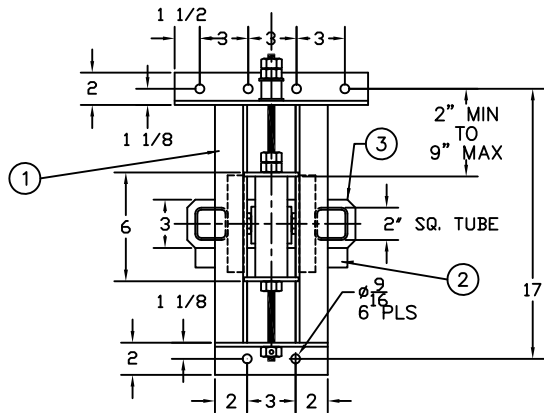
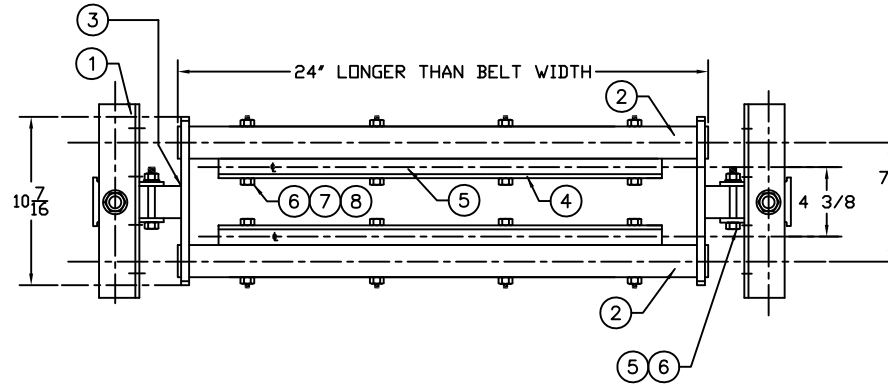

BELT WIDTH	"A"	
	MAX.	MIN.
12	35	15
18	41	21
24	47	27
30	53	33
36	59	39
42	65	45
48	71	51
54	77	57
60	83	63
66	89	69
72	95	75

DET	DWG. NO.	DESCRIPTION	QTY.
1	C-10-10S	SIDE FRAME ASSEMBLY	2
2	DS-11-21	TUBE	2
3	C-14-6S	TOGGLE PLATE WELDMENT	2
4	CS-11-22	BACKING BAR	2
5	CS-11-17	WIPER BLADE	2
6		3/8-16 SPLIT LOCKWASHER	A.R.
7		3/8-16x4 HEX HEAD BOLT	A.R.
8		3/8-16 HEX NUT	A.R.

THIS DRAWING IS COMPUTER GENERATED.			
DWN	RM	DATE	9/7/79
CKD		DATE	
APD	CLO	DATE	9/22/82
THIS PRINT IS THE PROPERTY OF CONVEYOR COMPONENTS CO. AND MUST NOT BE USED IN WHOLE, OR PART WITHOUT WRITTEN PERMISSION.			
PART NO.		DWG. NO.	REV.
		D0100009	B
PLEASE RETURN ON DEMAND.		SCALE 1=1/4	SHT. 1-1

DWG. NO. D0100009 SHT. 1-1 REV. B